

Interactive Light Up Rainbow Panel

SP7193

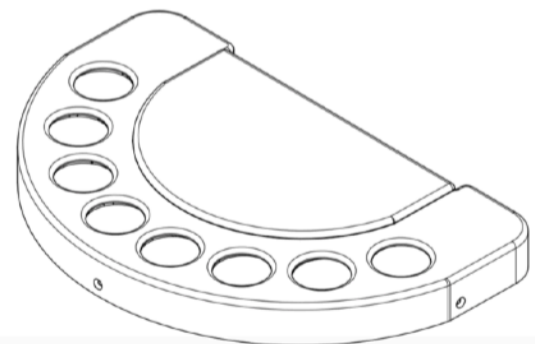
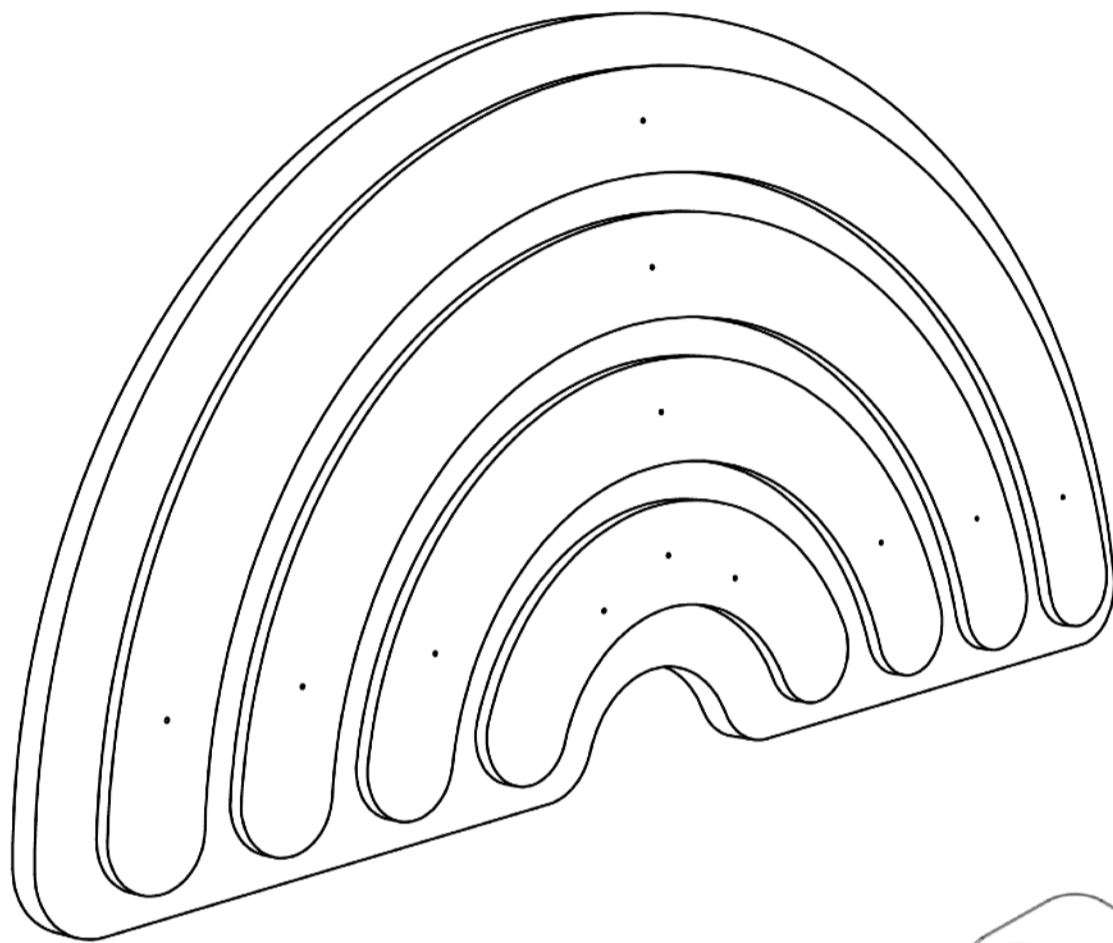

Installation Manual

14508-09
November 2022



Contents

Warnings	3
Description	3
Includes	3
Installation	4-6
8 Way Remote	7-8
Troubleshooting	8
Cleaning	8
Maintenance	8
Guarantee	9
Information	10
Technical Contact	11



Warnings

- * All our equipment is designed for users with special needs. We suggest supervision at all times when using this equipment.
- * For indoor use only. The panel uses a mains power supply. Do not use any other power cord than the one supplied.
- * This product was not designed to be free standing. It must be attached to a wall at least 4 feet (1220mm) from the floor. The electrical outlet should be placed next to the rainbow. Professional installation is recommended.
- * Turn off the panel when cleaning. Use a mild detergent and a lint free cloth. Never use abrasive cleaning pads to clean this item.

Description

Create a calming environment with a light up rainbow wall panel. This rainbow-shaped wall panel has concealed LED strips, which add a colorful, ambient glow to any darkened room. Use the included remote to have the lights cycle through an automatic sequence of colors or press a colored button to choose the color of choice. Install in your sensory space to help develop color recognition, practice cause and effect, improve visual tracking and encourage self regulation.

Includes

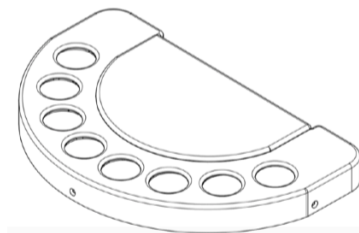
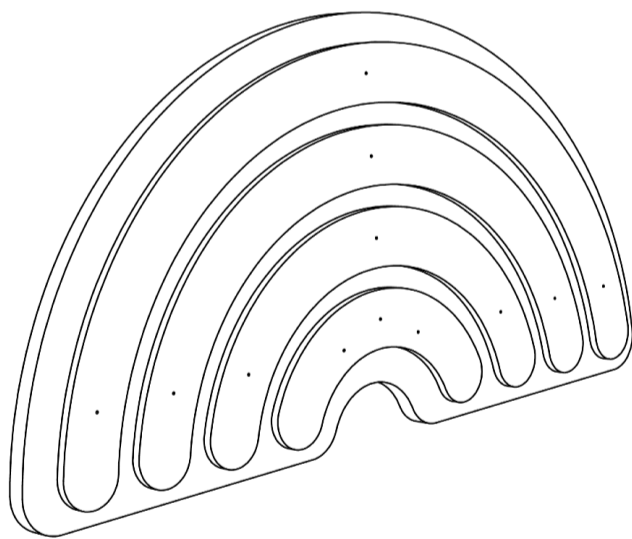

8 Way Remote

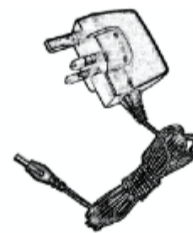

Power Cord

Rainbow Panel is fitted with a power cord

2 off Wall Brackets



1 off Mirror Plate



+

2 off 8 x 3/4 wood screws



(wood screws to be used to attach the mirror plate to the back of the panel)

Carefully check all parts are included in your packaging. Contact us immediately if parts are missing.

Installation

The Rainbow Panel is designed to be installed on the wall with the supplied brackets. Screws should be used that are recommended for the type of wall the panel will be installed on (wall installation screws are not included). Professional installation is recommended. The panel should be installed close to an electrical outlet.

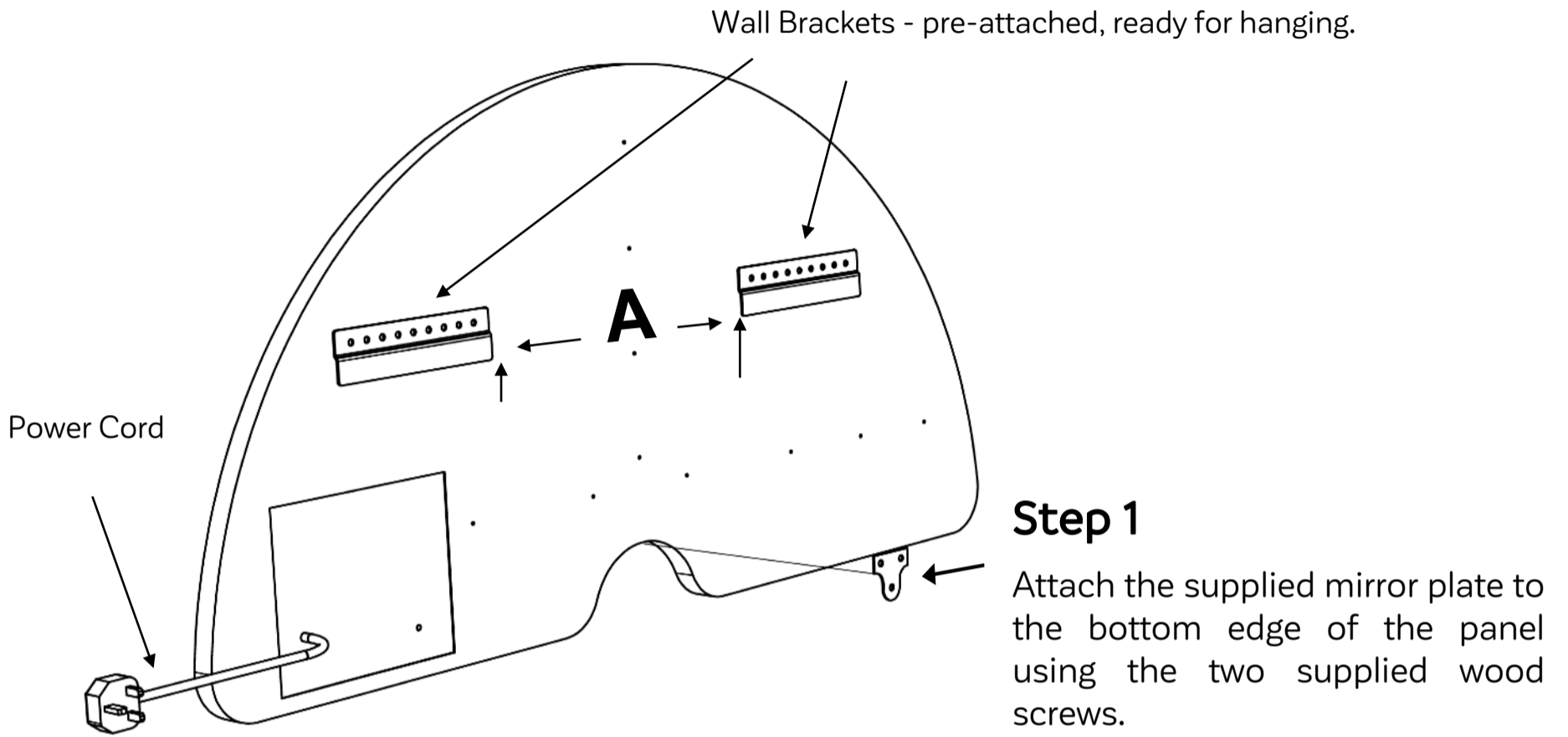

Step 2

Attach the two supplied brackets to the wall using suitable screws for the type of wall to be installed on. Set the top brackets at least 4 feet (1220mm) above the floor and the horizontal placement at distance of "A" shown on the drawing above. Make sure all attachment hardware can support up to 50 lbs. (22 kg) of weight.

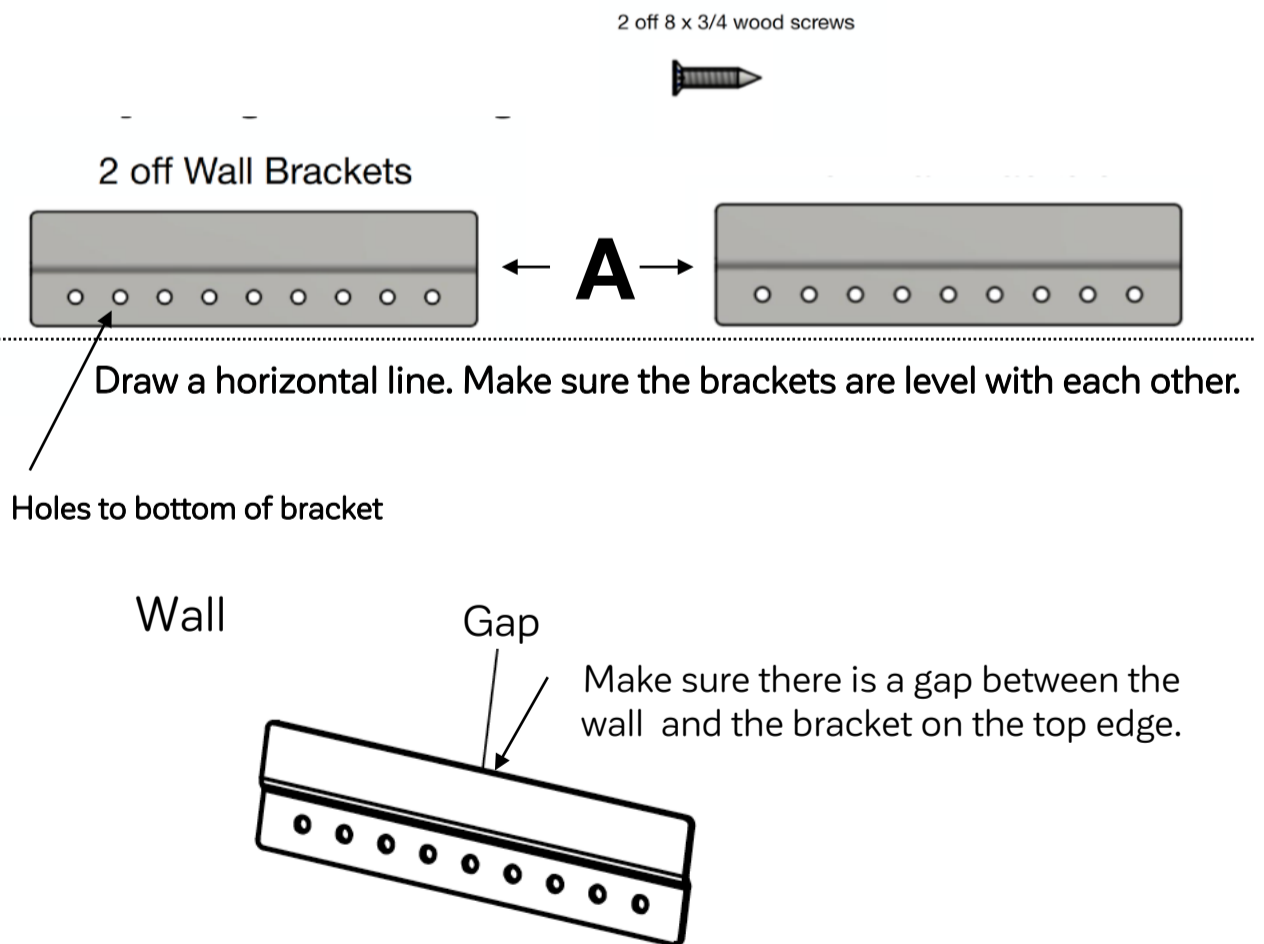

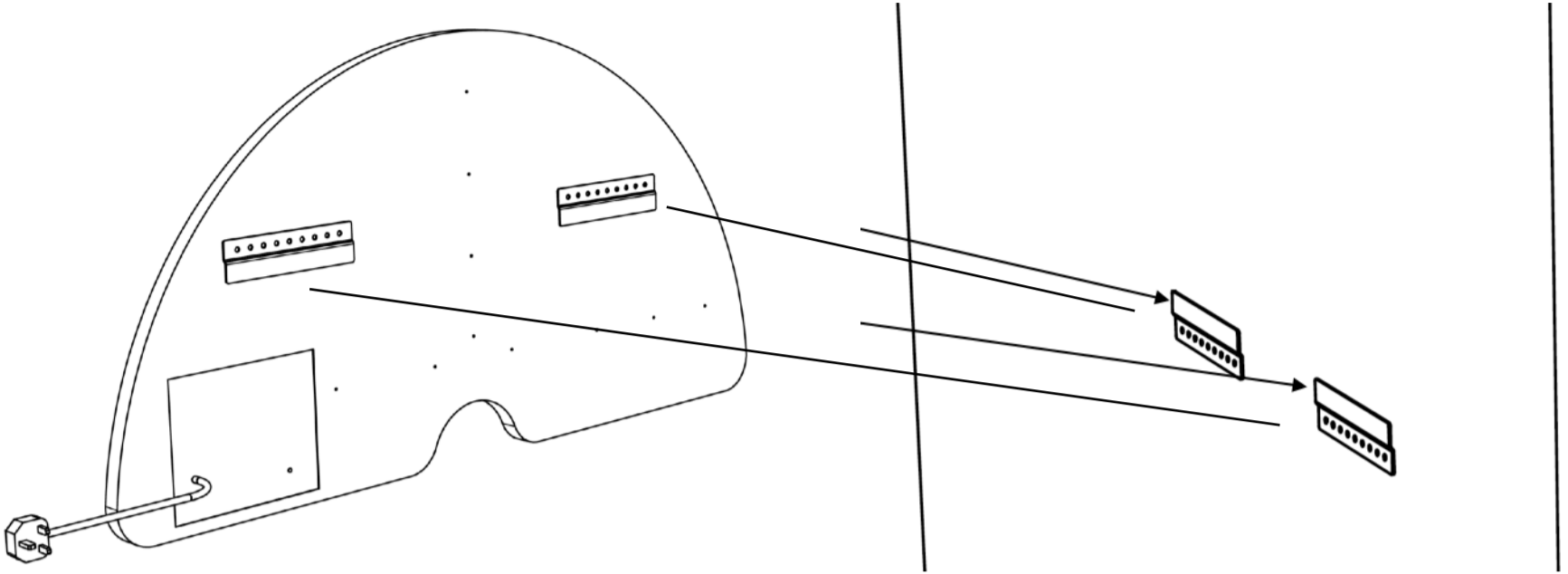

Step 3

Hook the brackets located on the back of the panel onto the wall brackets attached to the wall. Note: Lift the panel gently and set slowly into place until the brackets are securely and correctly connected.

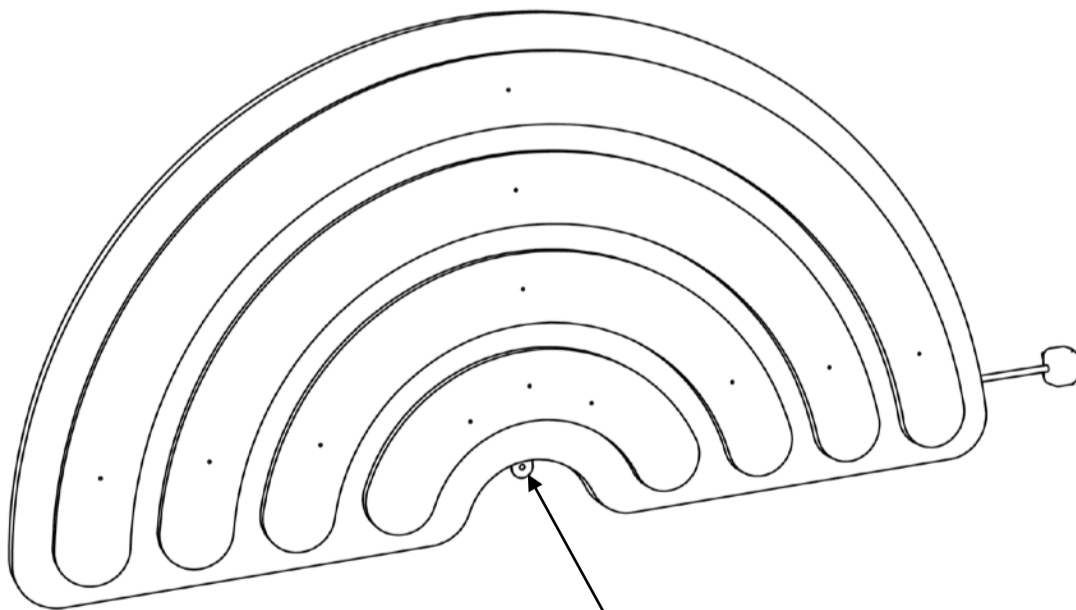

Step 4

To keep the rainbow from moving, place a screw into the wall through the mirror plate.

Connect Power

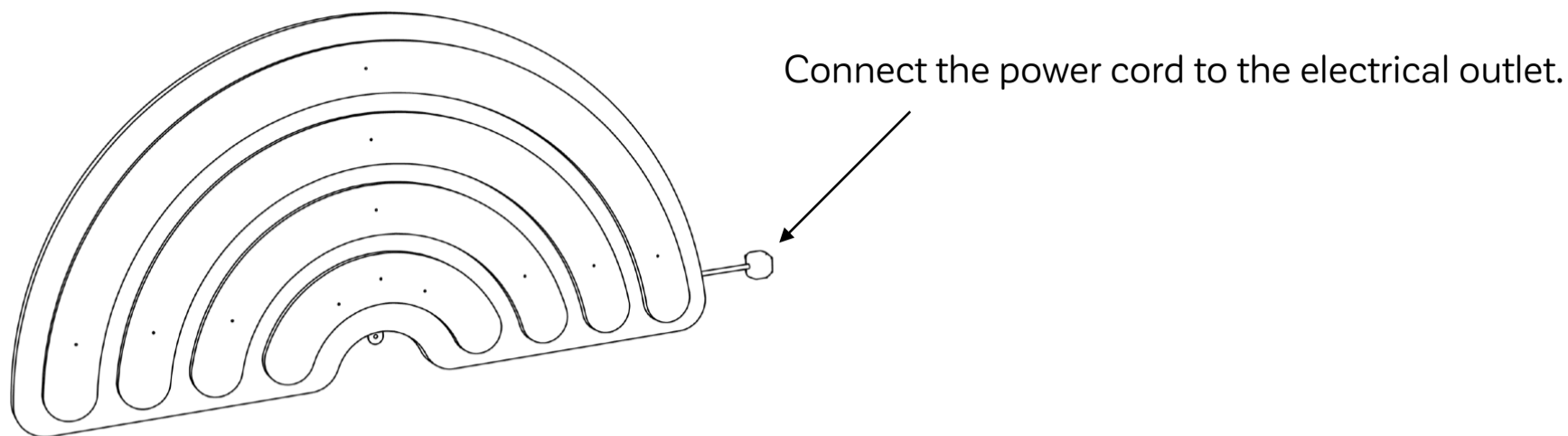

When the power supply is connected the Rainbow will illuminate. This will go through an automated color change until one of the buttons is pressed on the 8 way remote.

Press one of the buttons to change to the desired color. If the switch is not pressed, it will revert to the auto program after 45 seconds.

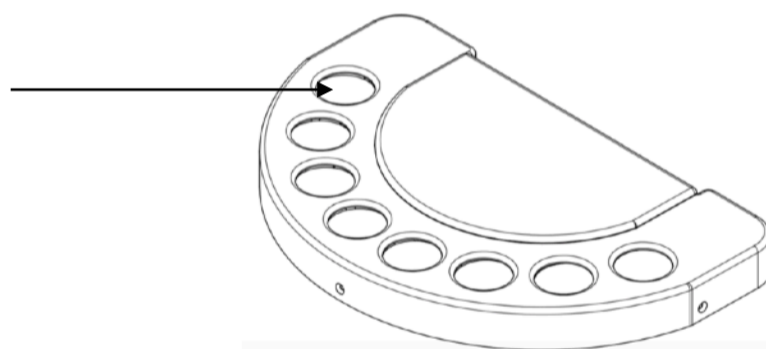

Troubleshooting

Q - My Rainbow Panel will not work.

A - Check the power supply is connected and operational and your 8 way remote is charged and the LED on the underside is illuminating green when a button is pressed.

Cleaning

To clean your Rainbow Panel, wipe with a soft white cloth and mild detergent. Never use an abrasive cloth or any solvent such as mineral spirits or chlorine based products. Always unplug the power cord when cleaning.

Maintenance

Your Rainbow Panel requires no maintenance except a visual inspection for a damaged front panel. Periodically, check all wall attachments and make sure the panel is secure. Make sure all electrical cords are not damaged and still intact.

8 Way Remote Instructions

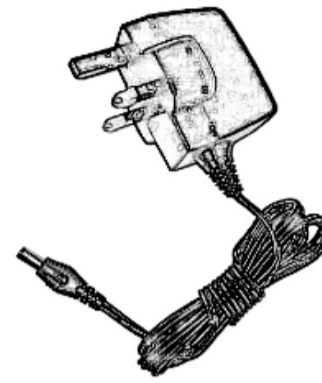
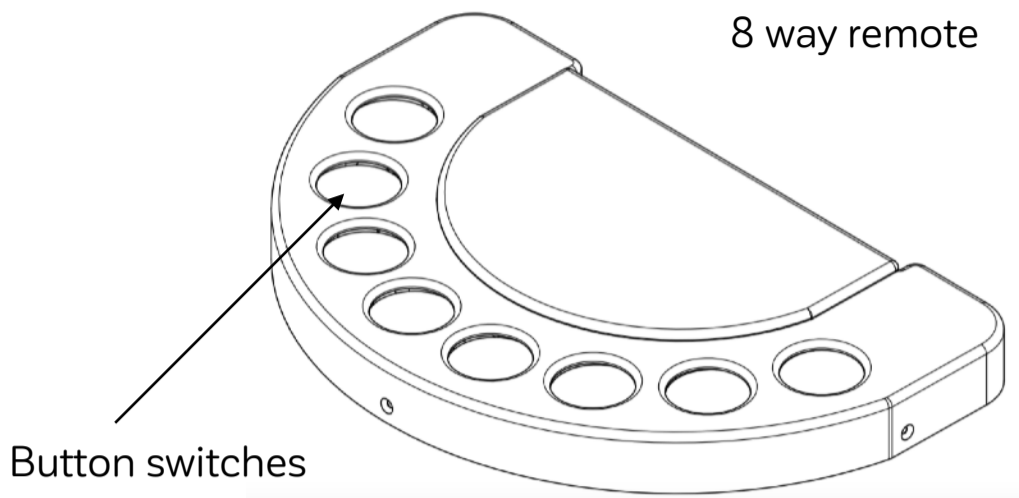

Power adapter/charger
Mains 240/110 v ac - 5 v dc

8 Way Remote

The 8 way remote is an 8 channel remote designed to be used with SpaceKraft multi-sensory equipment. It communicates using wireless technology on WiFi frequencies. It uses rechargeable battery technology to give longer operational use and is supplied with a 5v dc a power adapter/charger.

Operation

Press any one of the eight button buttons to activate. The remote will turn off automatically when not in use.

Charging

Charging your remote. Plug the power adapter/charger into the electrical outlet and then the adapter into the rear of the switch. Charge until the status light glows green. Please allow 12 hours for a full charge.

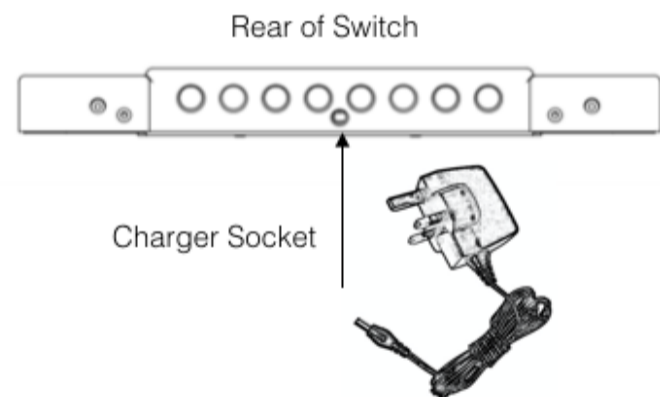

The remote has a status LED on the underside to inform you of the current state of battery and transmission data:

- Five short yellow flashes after a button is pressed reports low battery.
- A steady yellow light reports that the charger is connected and the remote is successfully charging.
- A steady green light reports that the charger is connected and the switch is fully charged.
- A flashing red light when any of the 8 buttons are pressed indicates the signal from the remote is not being received.

Jack Inputs

The rear of the remote is fitted with 8 x 6.3 mm Jack sockets . This allows users to plug in their favourite remote. These start from the rear view as switch 1 on the right hand side . Number 8 being on the left. The remote must be volt free and must be the normally open type.

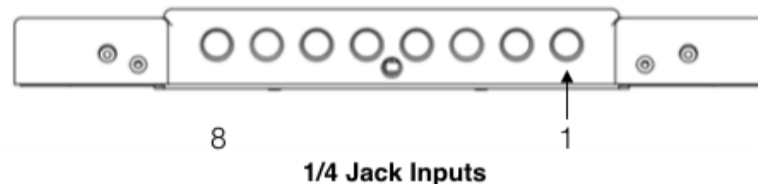

Remote Reset

The 8 way remote like all electronic equipment occasionally hangs or crashes. Should this happen, perform a hard reset. On the underside of the remote, a reset switch is clearly marked. Press a ball point pen into the reset switch and hold for 5 seconds and release. The switch will now re-boot.

Troubleshooting

Q - My remote will not work.

A - Check the status LED on the underside . If nothing is illuminated when pressing the button switch, reset the remote and charge for 12 hours.

Q - My remote will not work but the status LED flashes red.

A - The switch is working but the receiving piece of equipment is faulty or not turned on.

Q - My remote has been on charge and I have reset but the status led will not illuminate .

A - There is a problem with the charger.

Cleaning

To clean your remote wipe with a soft white cloth and mild detergent. Never use an abrasive cloth or any solvent such as mineral spirits or chlorine based products. Always unplug the power cord when cleaning.

Maintenance

We suggest your remote is tested every two years for correct operation and battery replacement. For service and technical contact us using the contact detail on the last page.

Guarantee

CONDITIONS OF GUARANTEE

This guarantee is in addition to and does not in any way affect any statutory or other rights of consumer purchasers. If within the applicable guarantee period (as shown in 8 below) the appliance proves to be defective by reason of faulty design, workmanship or materials, we undertake subject to the following conditions to have the defective appliance (or any part or parts thereof) repaired or at our discretion replaced free of charge.

1. The appliance shall have been purchased and used solely in accordance with Standard operating instructions and the technical and/or Safety Standards required in the country where this appliance is to be used
2. All enquiries must be through such dealers. For appliances used in the UK., U.S.A., Channel Islands, Isle of Man, and Republic of Ireland the appliance should be returned together with this guarantee and proof of purchase promptly on being found defective, at the purchasers risk and expense, to the authorised dealer from whom the appliance was purchased.
3. This guarantee shall not apply to damage caused through fire, accident, misuse, Wear and tear, neglect, incorrect adjustment or repair, to damage caused through where this appliance is used, or to damage occurring during Installation, adaptation, modifications, or use in an improper manner or inconsistent with the technical and/or safety standards required in the country transit to or from the purchaser.
4. If at any time during the guarantee period any part or parts of the appliance are replaced with a part or parts not supplied or approved by us or of an objective quality safe and suitable for the appliance, or the appliance has been dismantled or repaired by a person not authorised by us, the purchaser shall not be entitled to any rights and/or remedies under this guarantee.
5. The purchaser sole and exclusive remedy under this guarantee against us is for the repair (or at our discretion the replacement) of the appliance or any part or parts and no other remedy, including, but not limited to, incidental or consequential damage or loss of whatsoever nature shall be available to the purchaser.
6. This guarantee shall not apply to lamps, batteries, color filters, cabinet parts or any other parts of a limited natural life.
7. Our decision on all matters relating to complaints shall be final. Any appliance or Defective part which has been replaced shall become our property until paid for in full.
8. The guarantee period applicable to all new appliances shall be 24 months.



Information about products that generate electrical noise

USA and Canada

This device complies with FCC and industry Canada RF radiate exposure limits set forth for general population. It must not be colocated or operating in conjunction with any other antennas or transmitters.

This device complies with Part 15 of the FCC rules. Operation is subject to the following two conditions: 1 This device must accept any interference received, including interference that may cause undesired operation.

This equipment complies with the limits for Class B digital device, pursuant to Part 15 of the FCC Rules. These limits are designed to provide reasonable protection against harmful interference in a residential installation. Should problems occur reorient or relocate the receiving antenna. Increase the separation between the equipment and the receiver. Connect to a power outlet on a circuit different from that to which the receiver is connected.

Technical - Rainbow Panel

The Rainbow uses a power supply that is double insulated. A class 2 device does not require portable appliance testing. We do however suggest an annual visual inspection looking for any damaged parts.

The LED never need replacing and have a life expectancy of around 50,000 hrs. In real terms, a life expectancy of around 10 years.

Electrical Data

Supply Voltage	110/240	AC
Power Supply Primary Voltage	110/240	AC
Power Supply Secondary Voltage	12	DC
Power Supply Current rating	3	Amp
Power Supply Plugtop Fuse - UK	3	Amp
Working Load Current	1.6	Amp
Power Supply Compliance	EN - FCC	

Complies to:
BS EN 60355-1
Generic EMC standards -
Emission standard for residential, commercial and light-industrial environments

The power supply is fitted with a 3 Amp fuse . Disconnect the mains supply before attempting to replace .

Technical - 8 Way Remote

Power supply - 5v dc @ 2.1 amp - Switch mode. The 8 way remote uses radio technology extensively . This is based in the WiFi spectrum, Band 1 -2.4 Ghz

This is a low voltage device and does not require PAT testing.

Panel - 44.5"L x 22"W. Weighs 33 lbs.
1130mm x 559mm. 15 kg
Remote - 12" x 8" x 1.4". Weighs 2.2 lbs.
310mm x 200mm x 35mm Weighs 1 kg

Disclaimer

No part of this manual may be reproduced in any form or by any means (graphic, electronic or mechanical, including recording, taping, photography or information retrieval system) without express written permission of the publisher of this material.

All information correct at date of publication.



fun & function

EMPOWERING DIFFERENT®

PO Box 11, Merion Station, PA 19066

QUESTIONS? call us at 800-231-6329 or email us at customer@funandfunction.com. We are committed to going above and beyond to address your questions, ideas and feedback.



SpaceKraft copyright November 2022